



# Allied piping products pa, inc.

Highland Business Park – 98 Highland Avenue

P.O. Box 878 – Oaks, PA 19456-0878

Phone (610) 666-5950 Fax (610) 666-7606

USA WATS (800) 345-6395

Email: Sales@AlliedPiping.com Web: www.AlliedPiping.com



## REINFORCING SADDLES

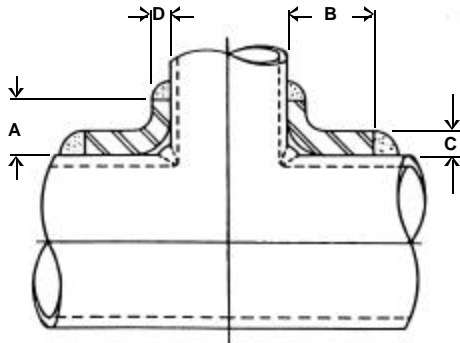

**Manufacture:** Saddles are made from A106 Gr. B or ASTM A516 grade 70. High Yield Saddles are made from A633 Grade E modified plate or API 5L X-grade seamless.

**Dimensions:** All dimensions are in inches. Dimensional tolerances can be provided upon request.

**Pressure-Temperature Ratings:** The saddle is not designed to contain internal pressure, but is to be used as a reinforcement which is slipped over the welded joint of branch pipe and header and then fillet weld skirt & nozzle to existing header pipe and outlet. A vent hole prevents entrapment of gasses during welding.

## WEIGHTS AND DIMENSIONS

Nominal Size of Pipe	Nominal Header Size	DIMENSIONS				Approx. Weights
		A	B	C	D	
1/4"	1/4 ~ 48	0.6250	0.7500	0.1875	0.2188	0.50 lb.
1/2"	1/2 ~ 48	0.8125	0.8750	0.1875	0.2188	0.50 lb.
3/4"	3/4 ~ 48	0.8125	1.2500	0.1875	0.2188	0.75 lb.
1"	1 ~ 48	0.8750	1.3125	0.1875	0.2188	1.00 lb.
1-1/4"	1-1/4 ~ 48	1.2500	1.3750	0.1875	0.2188	1.00 lb.
1-1/2"	1-1/2 ~ 48	1.5000	1.7500	0.2500	0.3125	2.00 lbs.
2"	2 ~ 48	1.6250	2.0000	0.2500	0.3125	3.00 lbs.
2-1/2"	2-1/2 ~ 48	1.5000	2.1250	0.2813	0.4063	4.00 lbs.
3"	3 ~ 48	1.5000	2.2500	0.3125	0.4063	5.00 lbs.
3-1/2"	3-1/2 ~ 48	1.7500	2.2500	0.3125	0.3750	6.00 lbs.
4"	4 ~ 48	1.7500	2.5000	0.3125	0.4375	7.00 lbs.
5"	5 ~ 48	2.0000	3.0000	0.3750	0.5000	12.00 lbs.
6"	6 ~ 48	2.5000	3.7500	0.4375	0.5000	22.00 lbs.
8"	8 ~ 48	2.7500	4.2500	0.4375	0.5000	33.00 lbs.
10"	10 ~ 48	3.0000	5.0000	0.4375	0.5000	45.00 lbs.
12"	12 ~ 48	3.5000	5.5000	0.4375	0.5000	57.00 lbs.
14 OD	14 ~ 48	4.0000	6.0000	0.4375	0.5625	76.00 lbs.
16 OD	16 ~ 48	4.0000	7.5000	0.4375	0.6250	107.00 lbs.
18 OD	18 ~ 48	4.5000	8.0000	0.5000	0.6250	152.00 lbs.
20 OD	20 ~ 48	5.2500	8.0000	0.5000	0.6250	163.00 lbs.
24 OD	24 ~ 48	6.0000	9.5000	0.5000	0.6250	248.00 lbs.

Intermediate sizes also available for prompt shipment. Skirts to fit pipe or pressure vessels of any size, pressure vessel heads and pipe caps. Heavier walls if desired—let us quote.